

* incl. 20 [-5; +30] mm pull out

3D model is available on request or www.hyva.com

Specifications		Max. pump flow		Tipping time	
Max. working pressure	250 bar	With KO ¹	70 L/min	With KO ¹	27 sec
Weight	114 kg	With KO ¹ below -20°C	49 L/min	With KO ¹ below -20°C	39 sec
Working volume	32 L			Allowable lowering time	27 sec
Total volume	34 L				
Max. cyl. load (start tipping)	310 kN				

Technical notes

- This cylinder is a lifting device only. • It should not be used as a structural member and should not be subjected to side loads. • Tipping valve must have a pressure relief at the cylinder port set not higher than max. working pressure. • Verify max. cyl. load.
- Working temperature range is between -40°C and +80°C. • Cylinder is painted black (RAL9005) with a min. thickness conforming to the 480 hours neutral salt spray test as per ISO 9227. • ¹ (Hyva) knock-off is required.

Related documentation

Cradle and bracket options:	015BRA19
Inlet adapters:	HPADAP02
Mounting instructions:	CYL-0043
Oil specifications:	OIL-0011
Spec sheet explanation:	CYL-0041

Configuration

Extension	1	2	3	4	5	6	7	8	9	10	11	Total
Effective diameter [mm]	214	191	169	149	129	110	93	77	61	45		2197
Stroke* [mm]	208	230	241	249	209	210	212	213	213	212		

Tipping weight

For detailed tipping calculations please refer to: <https://tipper.hyva.com>

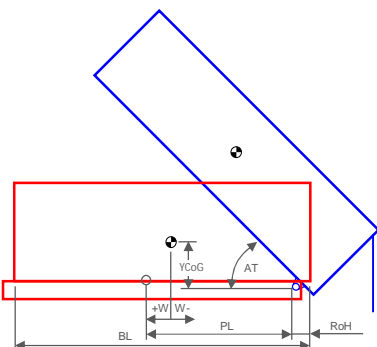

BL	body length [mm]		6600		6250		5900					
W	cyl. w.r.t. CoG [mm]	0	100	200	0	100	200	0	100	200		
PL	pivot length [mm]	2600	2700	2800	2425	2525	2625	2250	2350	2450		
ROH	rear overhang [mm]		200			200			200			
YCOG	vert. pos. CoG [mm]		700			700			700			
At	tip. angle full stroke	51	49	47	54	52	50	59	56	54		
At	tip. angle at stage 77	41	39	38	43	42	40	47	45	43		
	tipping weight	19	19	19	21	21	21	24	23	23		

Tipping weight [ton] at maximum pressure of 250 bar for a vertically mounted cylinder.

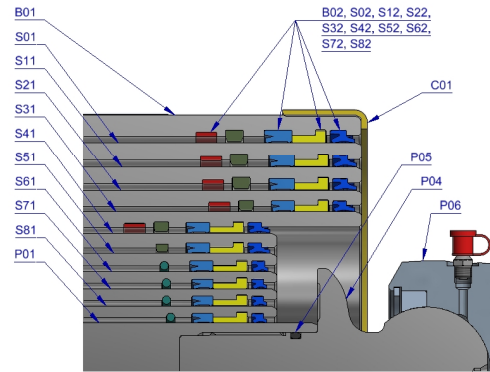
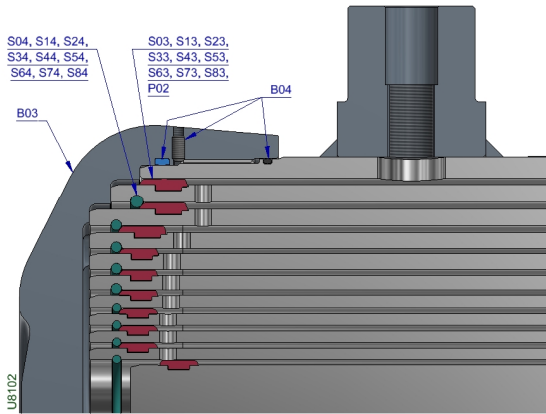

Pos.	Part no.	Description	Qty.
P01	73424081	PISTON UH 045-0295-HC	1
P02	73203045K	SLIDER UL 045 (2 X 1/2) A35 L=18	1
P04	73202010	SPHERE UH 60 FOR PISTON 045 FLANGED	1
P05	01225550K	O-RING 29.74 X 3.53 MM NBR 70 SHORE	1
P06	73202311K	RETAINER KIT UH SPH60	1

Pos.	Part no.	Description	Qty.
S41	73625081	STAGE UH 129-0298-HC	1
S42	73207129	PACKSET UH 129	1
S43	73203129	SLIDER FL 129 (2 X 1/2) A22-A35 L=18	1
S44	73110129	INNER STOPRING/LIFTRING UL 129	1

S31	73626203	STAGE UH 149-0338-HC-LT	1
S32	73207149	PACKSET UH 149	1
S33	73203149	SLIDER FL 149 A22-A35 L=18.3	1
S34	73110149	INNER STOPRING/LIFTRING UL 149	1

S21	73627201	STAGE UH 169-0338-HC	1
S22	73207169	PACKSET UH 169	1
S23	73203169	SLIDER FL 169 A22-A35 L=22.5	1
S24	71813169	LIFTRING FL 169x5	1

S81	73621081	STAGE UH 061-0298-HC	1
S82	73207061	PACKSET UH 061	1
S83	73203061	SLIDER UL/MN 061 (2 X 1/2) A35 L=18	1
S84	73110061	INNER STOPRING/LIFTRING UL 061	1

S11	73628205	STAGE UH 191-0338-HC-RS	1
S12	73207191	PACKSET UH 191	1
S13	73203191	SLIDER FL 191 A22-A35 L=22.5	1
S14	71813191	LIFTRING FL 191x5	1

S71	73622081	STAGE UH 077-0298-HC	1
S72	73207077	PACKSET UH 077	1
S73	73203077	SLIDER UL 077 (2 X 1/2) A35 L=18	1
S74	73110077	INNER STOPRING/LIFTRING UL077 / MN080	1

S01	73629181	STAGE UH 214-0328-HC	1
S02	73207214	PACKSET UH 214	1
S03	73203214	SLIDER FL 214 A22-A35 L=22.5	1
S04	71813214	LIFTRING FL 214x6	1

S61	73623081	STAGE UH 093-0298-HC	1
S62	73207093	PACKSET UH 093	1
S63	73203093	SLIDER UL 093 (2 X 1/2) A35 L=18	1
S64	73110093	INNER STOPRING/LIFTRING UL 093	1

B01	73528150	BASE UH 238-0314-N0186	1
B02	73207238	PACKSET UH 238	1
B03	73201238	THREADED BOTTOM UH 238	1
B04	73201738K	REPAIR KIT THREADED BOTTOM UH 238	1

S51	73624081	STAGE UH 110-0298-HC	1
S52	73207110	PACKSET UH 110	1
S53	73203110	SLIDER UL 110 (2 X 1/2) A22-A35 L=18	1
S54	73110110	INNER STOPRING/LIFTRING UL 110	1

C01	71838998	DUST COVER UM 214	1
-----	----------	-------------------	---

Seal kit complete

73208070K	Consists of all packsets with packset grease and O-rings
-----------	--

Notes

The inner stopring and piston bottom are pre-mounted on spare bases, stage and pistons. Therefore, when ordering new tubes, it is not required to order these parts separately.

For repair instructions see: CYL-0044. Serial no. is located on type plate and above or below trunnion at inlet side.