

HYVA CYLINDER



715 35 431

Front end cylinder with fixed eye

type

FE 149-4-05540-602J-K1649-HC

tipping weight

39-67 ton

page # 1 / 2

closed length (K)

1644-1679 mm

front & side view cylinder

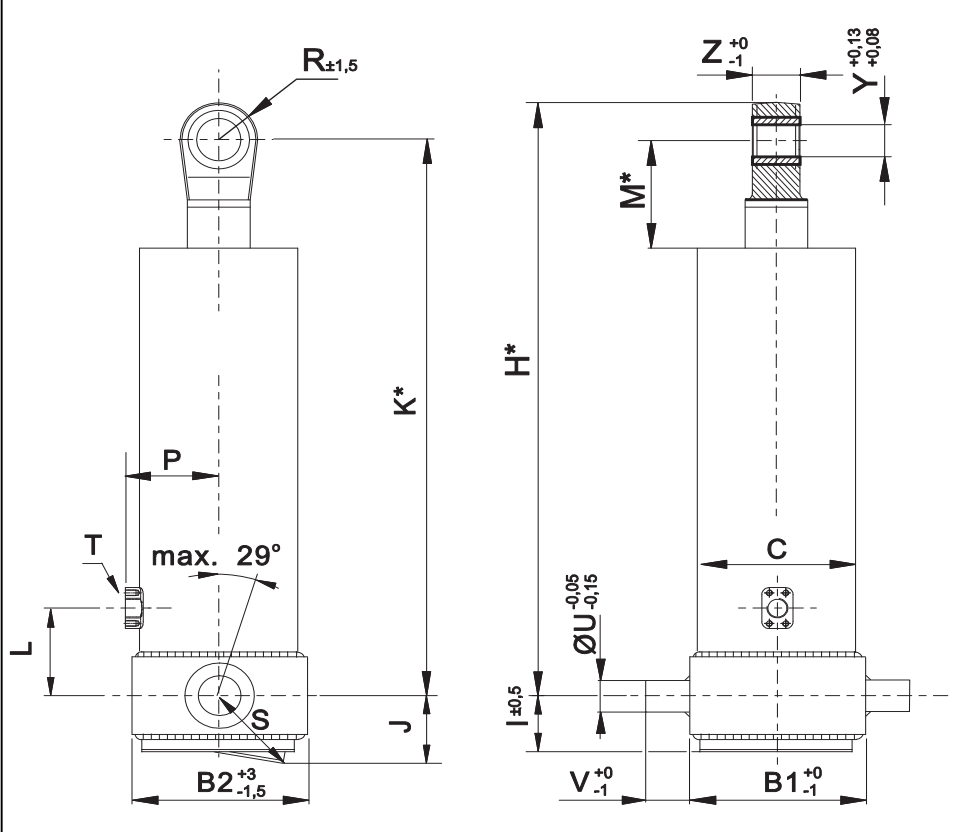

	1	2	
A			mm
B	201	201	mm
C	169		mm
D			mm
E			mm
F			mm
G*			mm
H*	1695		mm
I	75		mm
J	96		mm
K*	1649		mm
L	700		mm
M*	95		mm
N			mm
O			mm
P			mm
Q			mm
R	46		mm
S	114		mm
T	1" SAE		
U	60		mm
V	65		mm
W			mm
X			mm
Y	50		mm
Z	50		mm

*incl.20 [-5;+30] mm pull out on piston

specifications

weight cylinder only	197 kg
total volume	70 L
working volume	65 L
maximum pressure	220 bar
maximum pump flow	137 L/min
maximum cylinder angle to front	30 °
maximum thrust first stage**	30 ton

**when cyl. mounted at a large angle, thrust first stage may become too high: see Hyva Tipper Program

technical notes

This cylinder is a lifting device only and may not be used as structural member or be subject to side load. Working pressure depends on application; never exceed maximum pressure stated. Cylinder is painted black (RAL9005). Max duration of extension 0.5 hours (excluded HC). See specification sheet CYL-0019 for mounting instructions, OIL-0011 for oil specifications and 015BRA01 for bracket specifications.

extension	1	2	3	4	5	6	7	8	9	
effective diameter [mm]	149	129	110	91						total
stroke [mm]	1370	1390	1390	1390						5540

tipping weight

tipping weight at maximum pressure of 220 bar and C is 158 mm

	7300			7050			6800		
	BL	OH	At	BL	OH	At	BL	OH	At
Ycog									
600	39	42	46	40	43	48	41	45	51
900	42	46	51	43	47	54	44	50	58
1200	45	50	57	46	52	61	49	56	67

Subject to change without notice, no rights reserved.

DO-E 71535431 / 14-02-24 / RV AB

HYVA CYLINDER

715 35 431



Front end cylinder with fixed eye

type

FE 149-4-05540-602J-K1649-HC

page # 2 / 2

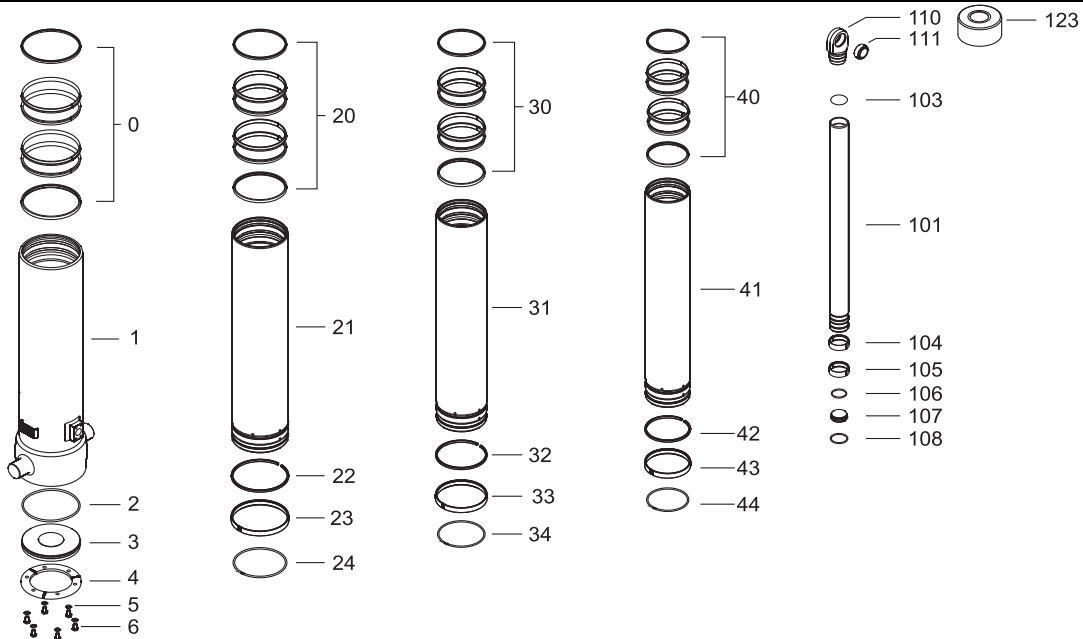

Spare part list

Pos Part no. Description Qty.

0	71802169 K	PACKSET FL 169	01
1	72526584	BASE 169-1629-4/4SAE-700 LR	01
2	71870035 K	SEAL BOTTOM PLATE 169	01
3	71821169	BOTTOM PLATE 169	01
4	71820169	LOCKING PLATE 169	03
5	01732559 K	SPRING WASHER M8 SET	01
6	01732055 K	BOLT M8 X 1.25 X 20 SET	01

20	71802149 K	PACKSET FL 149/HP 150	01
21	72615581	STAGE 149-1590 (V+SR=78)-HC	01
22	71811149 K	OUTER STOPRING FL 149	01
23	71807149 K	SLIDER FL 149	01
24	71812149 K	LIFTRING FL 149/HP 150	01

30	71802129 K	PACKSET FL 129/HP 129	01
31	72614581	STAGE 129-1590 (V+SR=78)-HC	01
32	71811129 K	OUTER STOPRING FL 129/HP 129 HD	01
33	71807129 K	SLIDER FL 129/GF 129 (2 X 1/2)	01
34	71812129 K	LIFTRING FL 129/HP 129	01

Spare part list

Pos Part no. Description Qty.

40	71802110 K	PACKSET FL 110	01
41	72613585	STAGE 110-1590 (V+SR=78)-HC	01
42	71811110 K	OUTER STOPRING FL 110/HP 110 HD	01
43	71807110 K	SLIDER FL 110/GF 110 (2 X 1/2)	01
44	71812110 K	LIFTRING FL 110	01

101	72412585	PISTON S 091-1595-HC (V+SR=78)	01
103	71870115 K	O-RING PISTON TOP 091	01
104	71811091 K	OUTER STOPRING FL 091/HP 091 HD	01
105	71807091 K	SLIDER FL 091 (2 X 1/2)	01
106	71870215	O-RING PISTON BOTTOM 091	01
107	71822091	BOTTOM PLATE PISTON 091	01
108	01745012	CIRCLIP 82 DIN 472 (87.5x2.5)	01
110	71837007	PISTON EYE SOLID 091 L=070 H=50 WD=70	01
111	01770227	BEARING BUSH EYE 5060-50	01
123	71838955	DUST COVER FE 149 YELLOW	01

Seal kit complete:

Part no. Description

71901540 K	Seal kit complete: consists of all packsets with packset grease and O-rings
------------	---

Notes:

The inner and outer stoprings are pre-mounted in the grooves on spare stages and pistons. Therefore, when ordering new tubes, it is not required to order stopring separately.