

Specifications

Max. working pressure	250 bar
Weight	364 kg
Working volume	118 L
Total volume	127 L
Max. cyl. load (start tipping)	345 kN
Max. cyl. load (end of stroke) ²	187 kN
Max. cyl. load (end of stroke) ³	218 kN

Max. pump flow

With KO ¹	190 L/min
Without KO ¹	170 L/min
With KO ¹ below -20°C	133 L/min
Without KO ¹ below -20°C	119 L/min

Tipping time

With KO ¹	37 sec
Without KO ¹	42 sec
With KO ¹ below -20°C	53 sec
Without KO ¹ below -20°C	60 sec
Allowable lowering time	37 sec

Extension	1	2	3	4	5	6	7	Total
Effective diameter [mm]	191	169	149	129	110			6480
Stroke* [mm]	1280	1300	1300	1300	1300			

Technical notes

- This cylinder is a lifting device only. • It should not be used as a structural member and should not be subjected to side loads. • Tipping valve must have a pressure relief at the cylinder port set not higher than max. working pressure. • Verify max. cyl. load. • Working temperature range is between -40°C and +80°C. • Max. duration of extension is 0.5 hours (excluded hard chromed stages). • Cylinder is painted black (RAL9005) with a min. thickness conforming to the 480 hours neutral salt spray test as per ISO 9227. • ¹ Hyva knock-off. • ² Unsubstantial unloading (sticky load). • ³ Substantial unloading.

Related documentation

Bracket options: 015BRA10 & 015BRA12

Mounting instructions: CYL-0030

Oil specifications: OIL-0011
Spec sheet explanation: CYL-0041

Tipping weight

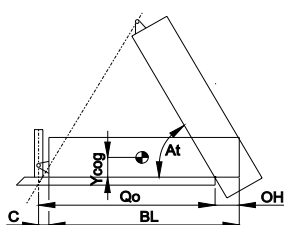

BL	body length
OH	rear overhang
Ycog	vert. pos. centre of gravity
Qo	pivot length
C	bracket length
At	tipping angle
	stroke x 60 / Qo

BL [mm]	8600			8150			7700		
OH [mm]	200	500	800	200	500	800	200	500	800
At [°]	45	46	48	47	49	51	50	53	55
Ycog [mm]									
600	65	70	75	68	73	80	71	77	
900	69	75		73					
1200	74								

Tipping weight [ton] at maximum pressure of 250 bar for a vertically mounted cylinder and C is 229 mm

For detailed tipping calculations please refer to: <https://tipper.hyva.com>

Alpha series - Front end cylinder with outer cover



FC A191-5-06480-014-K1050

Item no.

70527528

Pos.	Part no.	Description	Qty.
C01	71839050	DUST COVER FC LOW 15-273	1
C02	71737160	COVER 273-0605 PIN60 A360 SPH LOCK	1
C03	01702956 K	WASHER M48 DIN 125B ZP	1
C04	01702907 K	TOPNUT NYLOC M48x3 DIN 985 ZP	1
C05	01791953	O-RING COVER D.273	1
C06	15014550 K	BOLT HSHC M12X30X1.75 Q8.8 DIN 912 ZP	1
P01	74403511	PISTON FL2 S 110-1515-HC	1
P02	71853110 K	SLIDER FL 110 (2 X 1/2) A22	1
P03	71851110 K	OUTER STOPRING FL 110 A22	1
P04	71822110	BOTTOM PLATE PISTON FL 110	1
P05	01745050 K	CIRCLIP 100 DIN 472 (105.5x3.0)	1
P06	71870220 K	O-RING PISTON BOTTOM 110	1
P07	71848300	PISTON HEAD FL 110 MK2	1
P08	01226538 K	O-RING 91.67 X 3.53 MM NBR	1

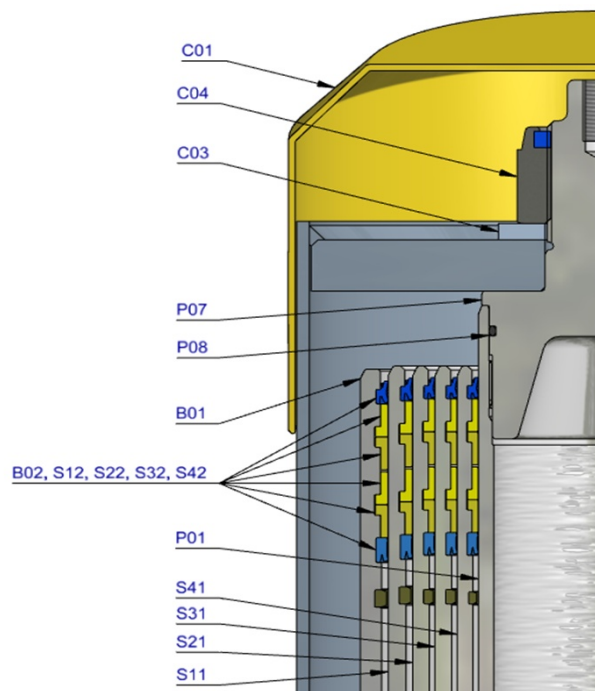

S41	74604510	STAGE FL2 129-1510	1
S42	71802129 K	PACKSET FL 129/HP 129	1
S43	71853129 K	SLIDER FL 129 (2 X 1/2) A22	1
S44	71851129 K	OUTER STOPRING FL 129 A22	1
S45	71852129 K	LIFTRING FL 129 A22	1

S31	74605510	STAGE FL2 149-1510	1
S32	71802149 K	PACKSET FL 149/HP 150	1
S33	71807151 K	SLIDER FL 149 A35	1
S34	71851149 K	OUTER STOPRING FL 149 A22	1
S35	71852149 K	LIFTRING FL 149 A22	1

S21	74606510	STAGE FL2 169-1510	1
S22	71802169 K	PACKSET FL 169	1
S23	71807171 K	SLIDER FL 169 A35	1
S24	71851169 K	OUTER STOPRING FL 169 A22	1
S25	71813169 K	LIFTRING FL 169x5	1

S11	74607510	STAGE FL2 191-1510	1
S12	71802191 K	PACKSET FL 191	1
S13	71807193 K	SLIDER FL 191 A35	1
S14	71851191 K	OUTER STOPRING FL 191 A22	1
S15	71813191 K	LIFTRING FL 191x5	1

B01	74508512R0505	BASE FL2 214-1561-4/4BSAE-290-C273	1
B02	71802214 K	PACKSET FL 214	1
B03	71825435	BOTTOM PLATE FL2 214	1
B04	71870045 K	SEAL BOTTOM PLATE FL 214	1
B05	71820214	LOCKING PLATE FL 214	3
B06	01732020 K	BOLT HEX M12X25X1.25 SET 6 PCS	1
B07	01732523 K	WASHER SPRING M12 SET 6 PCS	1

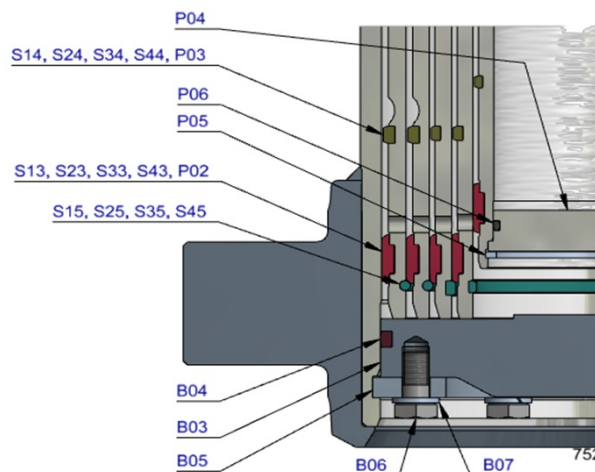
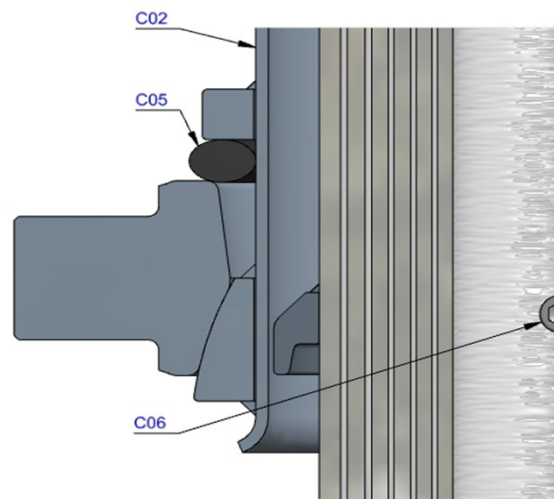

Seal kit complete

	71908750 K	Consists of all packsets with packset grease and O-rings	
--	------------	----------------------------------------------------------	--

Notes

The inner stopring is pre-mounted in the grooves on spare bases and stages. Therefore, when ordering new tubes, it is not required to order inner stoprings separately.

For repair instructions see: CYL-0040. Serial no. is located on type plate and near type plate support.